

Resistance Birds: Vermont Hermit Thrush

Foundation Paper Piecing Pattern















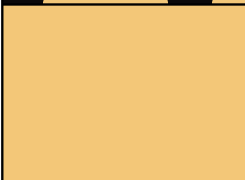

Finished Block: 12 inches x 12 inches

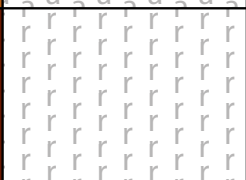

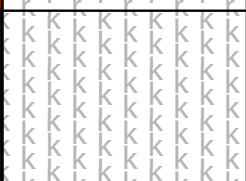
Coffee Town Quilting, LLC
coffeetownquilting.com | @coffeetownquilting

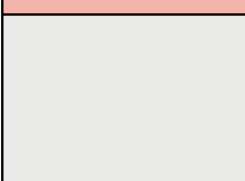
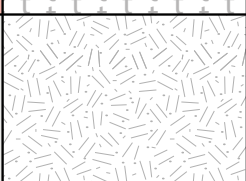
Color Guide and Fabric Chart

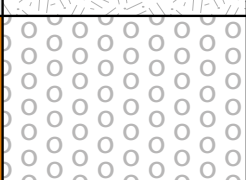
Color	Color Code	Yardage	Notes	Sample
		Fat Quarter	Halo, color of your choice	Paste Fabric Sample Here
		Fat Quarter	Patterned fabric, same shade as "b"	Paste Fabric Sample Here
		Fat Quarter		Paste Fabric Sample Here
		Fat Quarter		Paste Fabric Sample Here
		Fat Quarter		Paste Fabric Sample Here
		1/2 Yard		Paste Fabric Sample Here
		1/2 Yard	Background Circle, color of your choice	Paste Fabric Sample Here
		Fat Quarter	Background	Paste Fabric Sample Here
		Fat Quarter	Legs	Paste Fabric Sample Here

Recommendations:

- **Since this design has many small pieces to accommodate the bird's details, batik or thinner fabric is recommended for best results.**
- This pattern assumes you already have knowledge of FPP and have completed beginning or intermediate designs.
- Color Guides are on page 2, print in color if able.
 - Cut small swatches of the fabric you will be using for each color code and paste them next to the corresponding square in the Color Guide grids.
 - Keep grid close to your cutting and sewing table as a legend and a reminder of which fabric is used for each color code.
 - The final page of the pattern is a grayscale and outline of the pattern, feel free to print and audition different color schemes according to your preference.
- Print the pattern pieces on newsprint paper if available for easy paper removal.
- Sew straight stitch with stitch length 1.5 - 2.0.
- Use an 80 wt or thinner thread for piecing to help keep seam bulk at minimum.
- In more complex areas with small pieces, consider trimming to 1/8" seam allowance.
- Remove paper backing from seam allowance before ironing when piecing separate sections together, this will help reduce bulk from sections pieced together and make final paper removal easier.
- Instructions and videos with helpful hints how to successfully line up and piece together cross seams across blocks are on my website coffeetownquilting.com.
- Once pieced, remove paper, spray liberally with ironing starch, and press well before adding border and quilting.

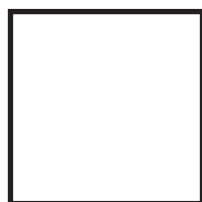

1 inch square:

Measure printed page
to ensure measurement
accuracy

Section Map

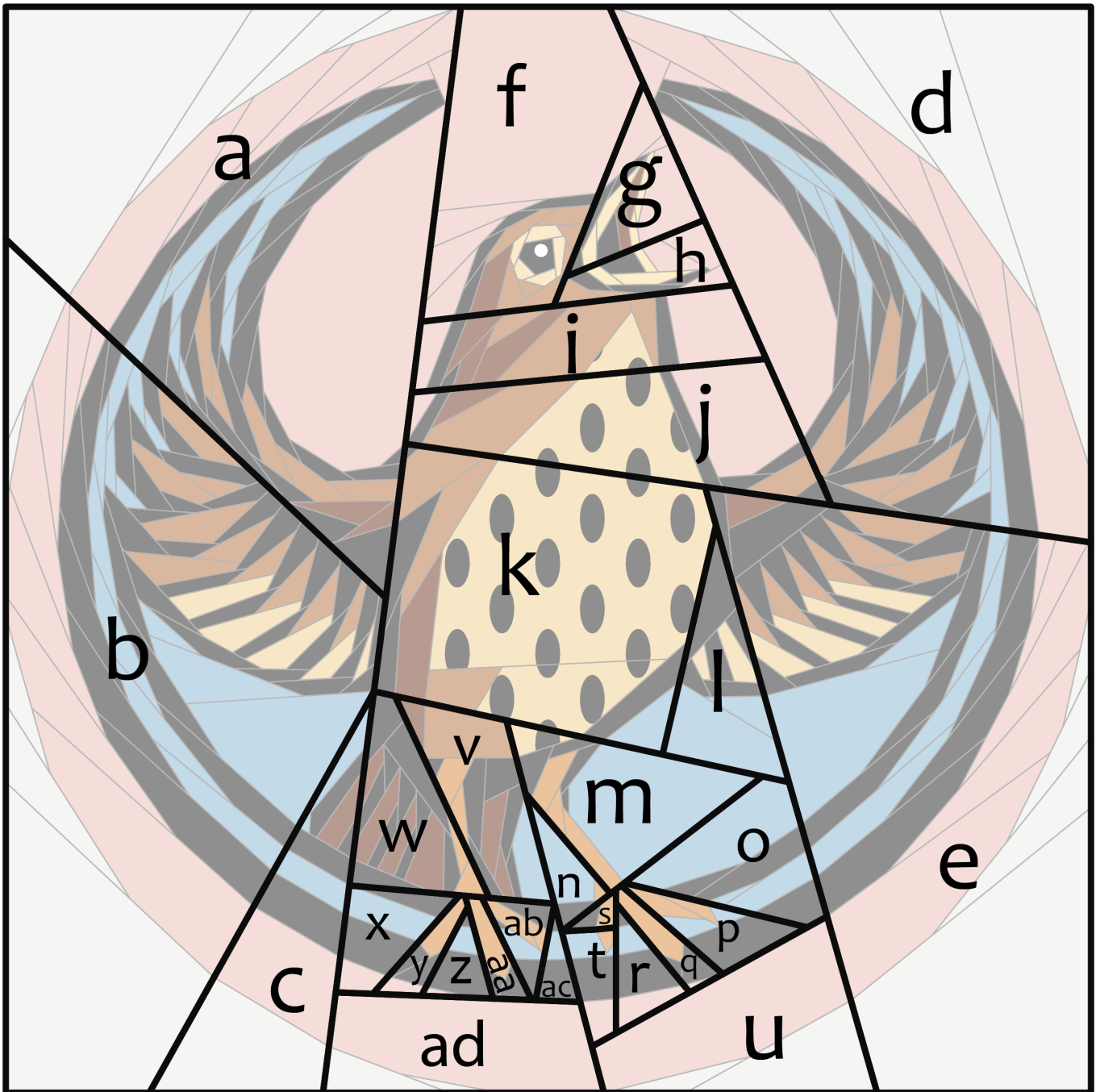

Section 1

1. $a + b + c$

Section 2

1. $f + (g + h)$
2. $fgh + i + j$
3. $fghij + d$

Section 3

1. $k + l$

Leg 1

1. $m + n$
2. $(s + t)$
3. $o + p + q + r$
4. $opqr + st$
5. $m + opqrst + u$

Leg 2

1. $v + w$
2. $x + y + z$
3. $aa + ab + ac$
4. $xyz + aaabac$
5. $vw + x...ac + ad$

Subsection Piecing

1. $kl + (\text{Leg1} + \text{Leg2})$

Final Piecing

1. Section 2 + 3
2. Section 1 + Sections 2:3

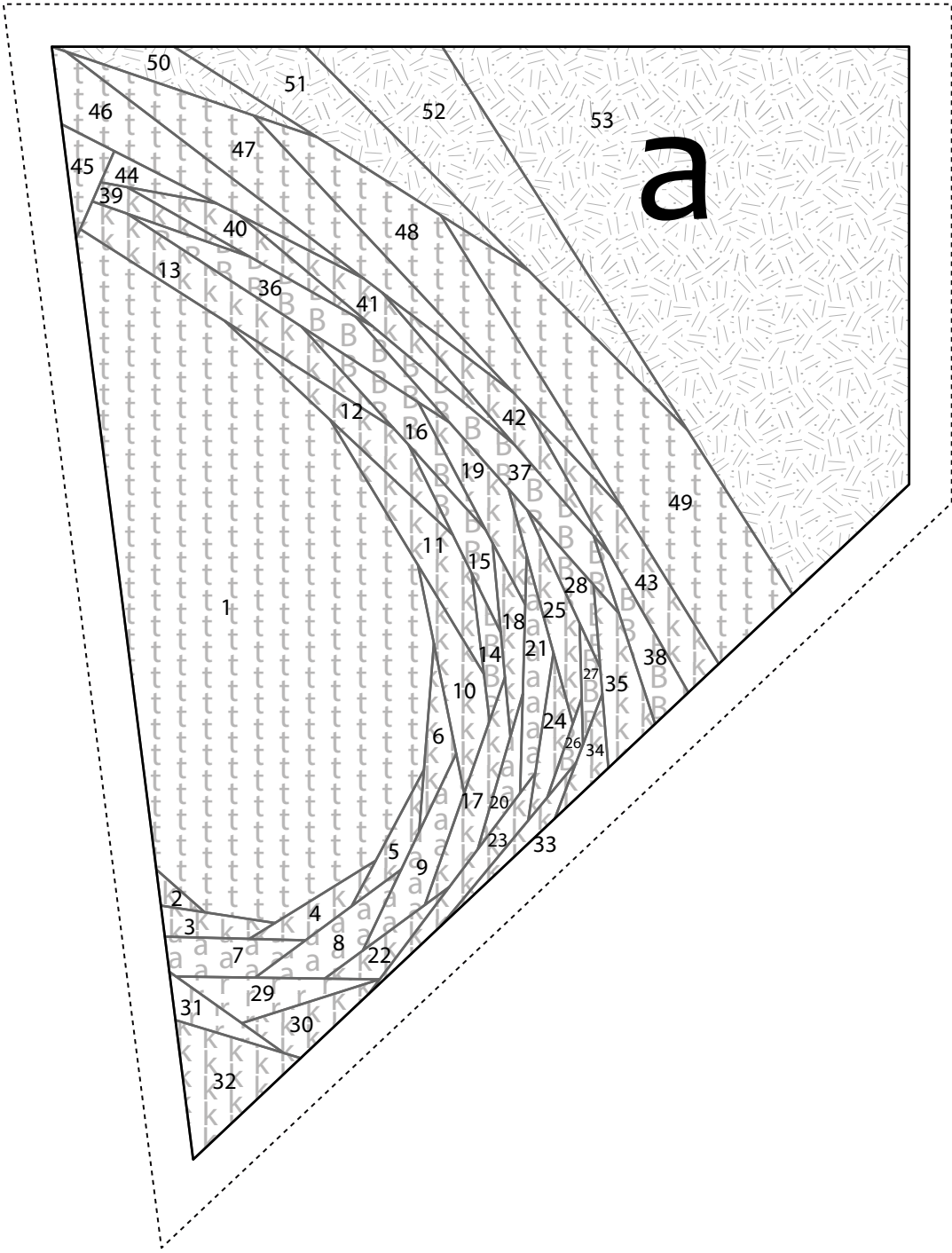

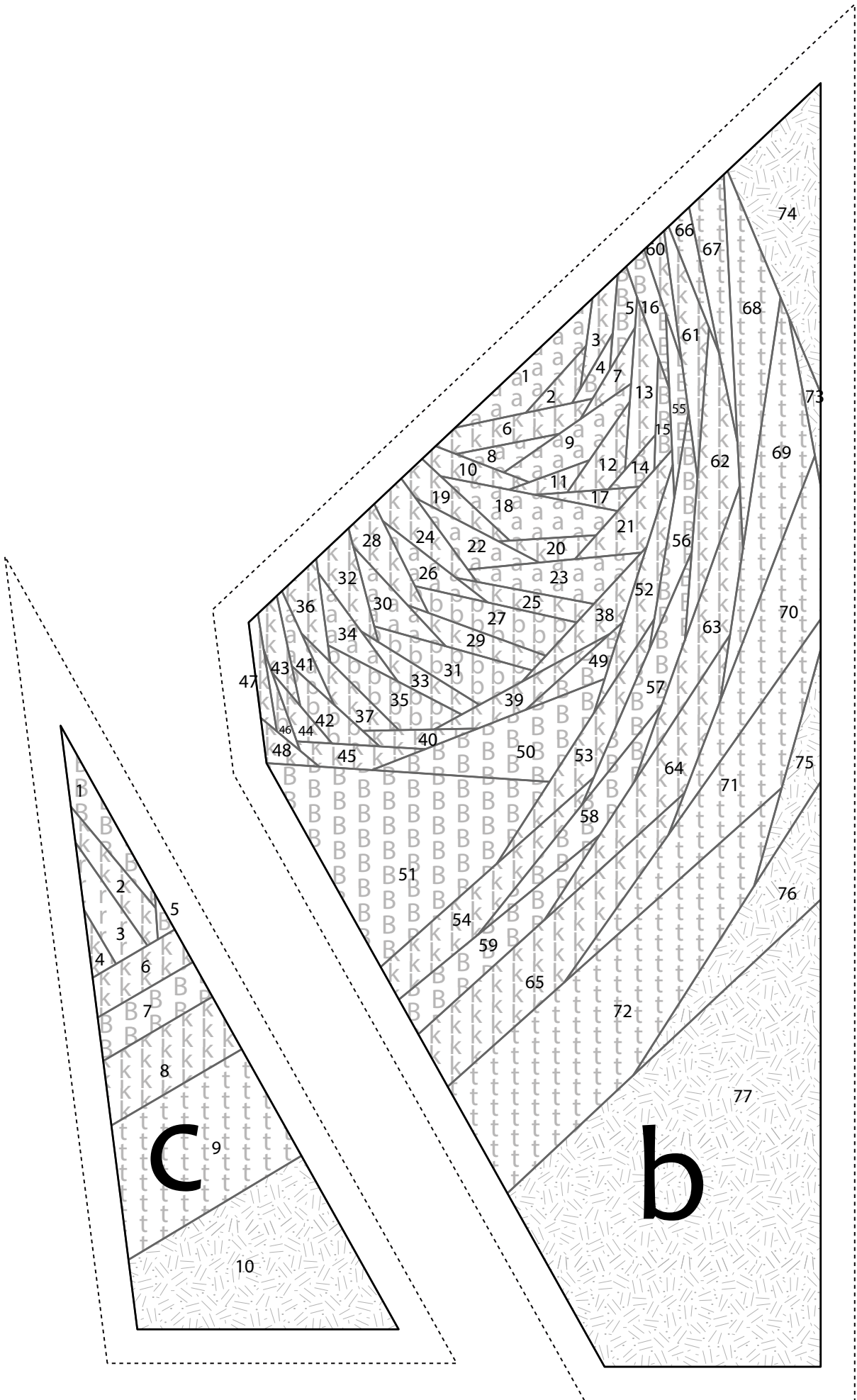

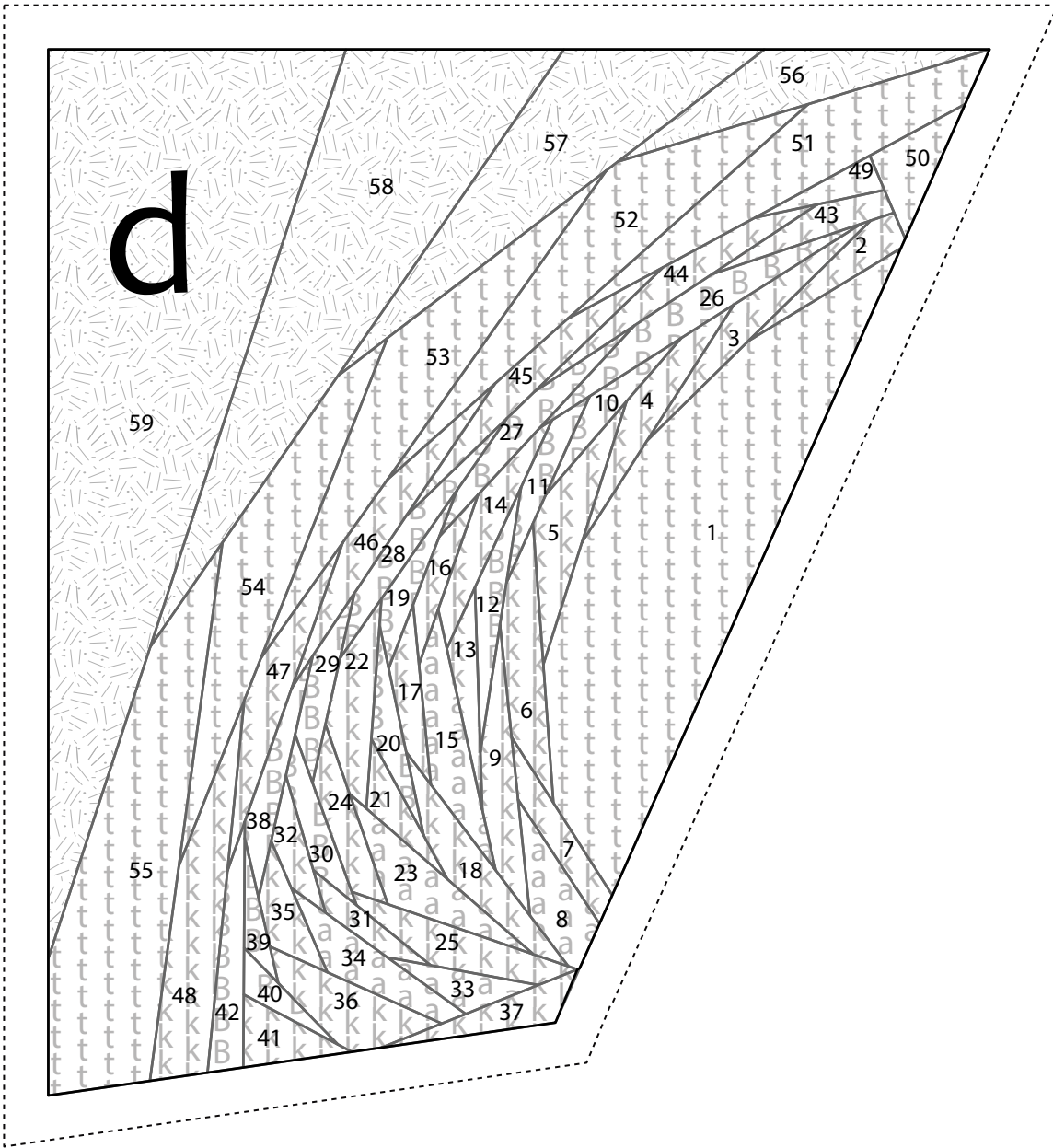

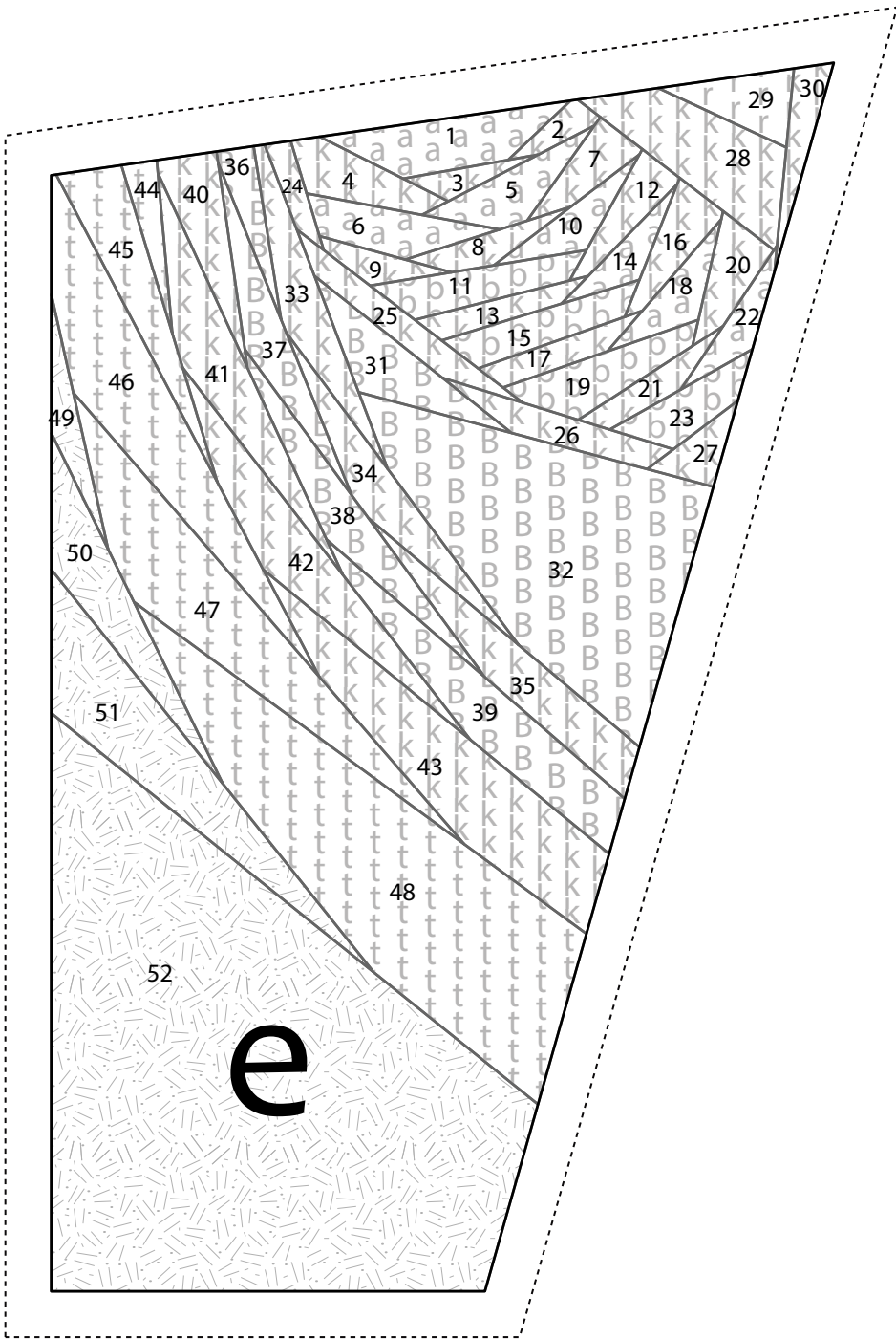

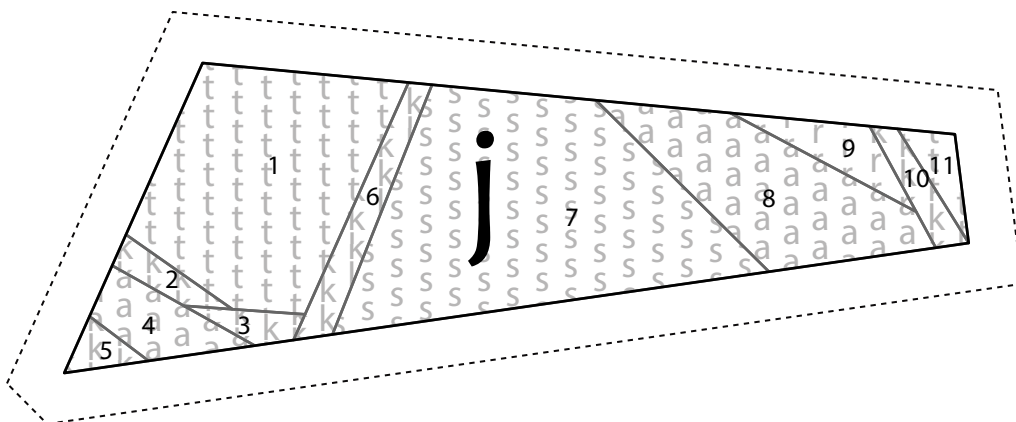
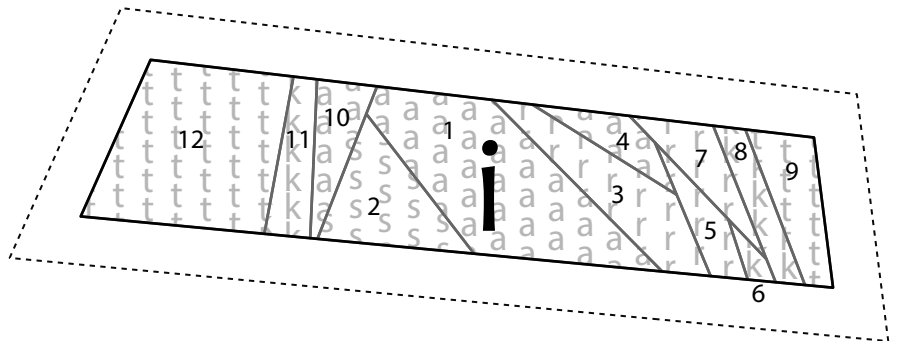
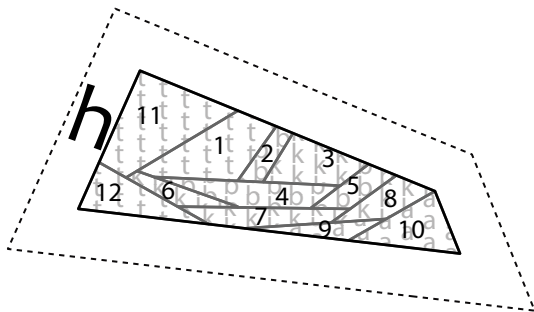
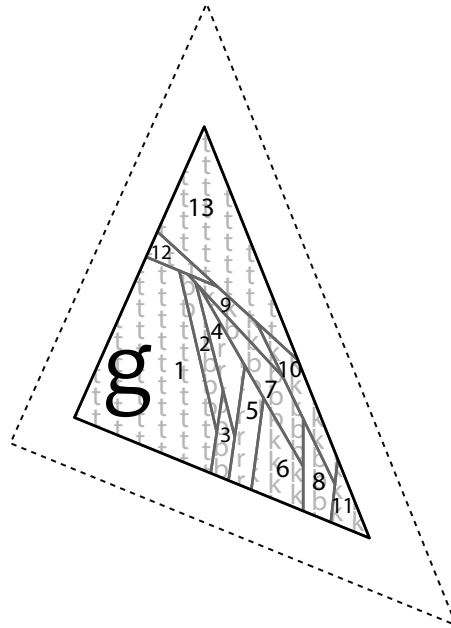
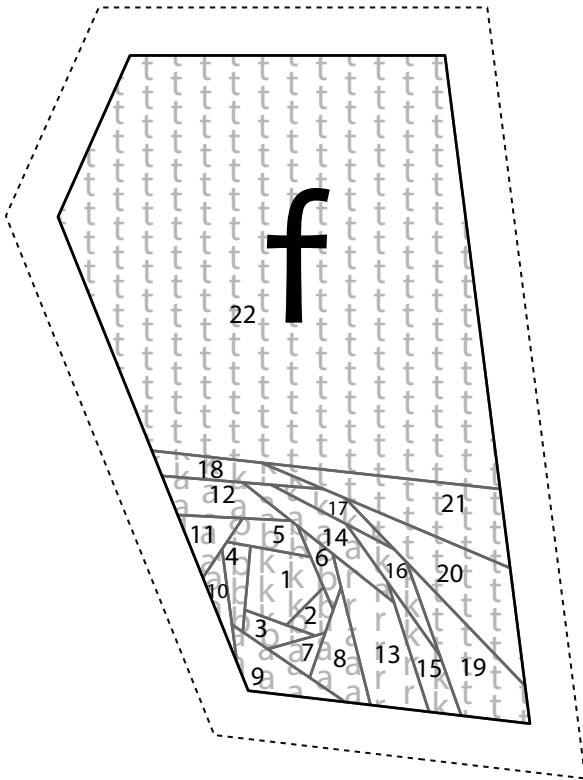

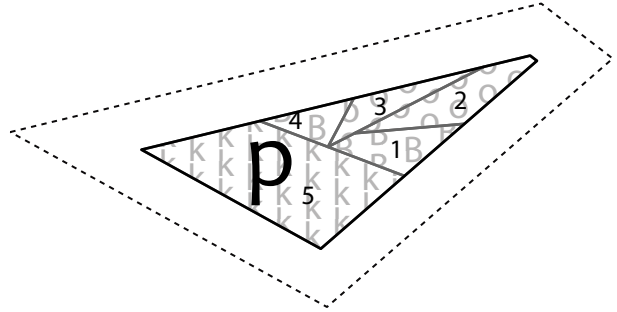
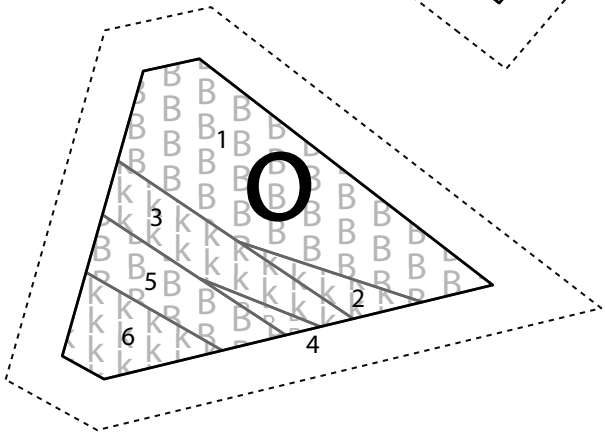
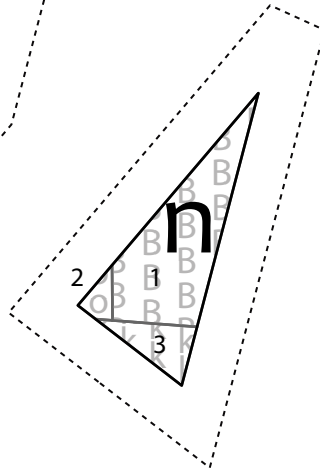
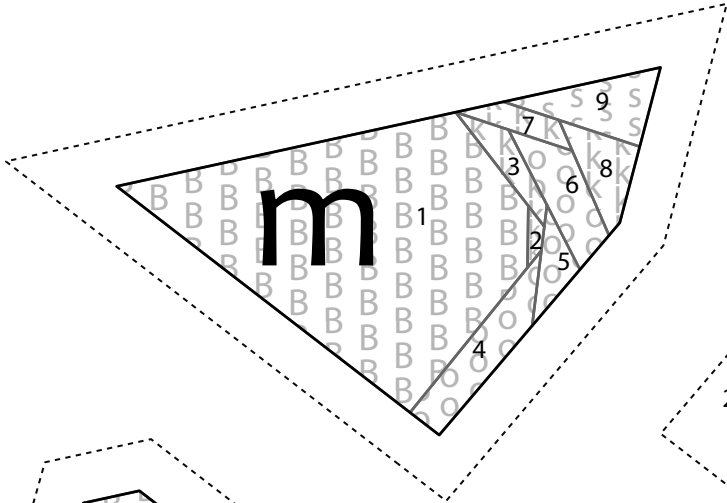
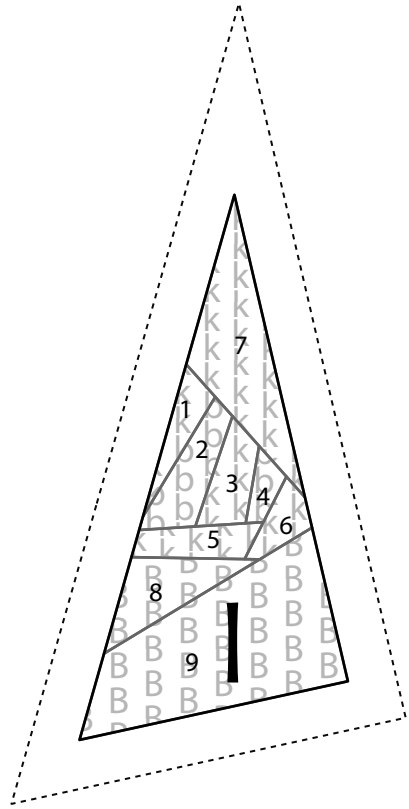
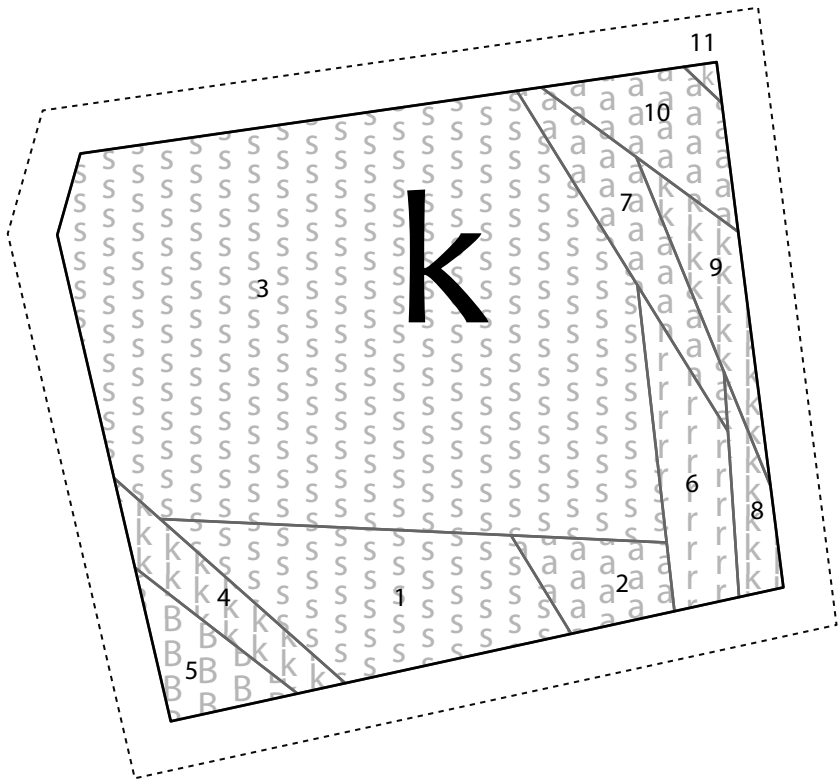

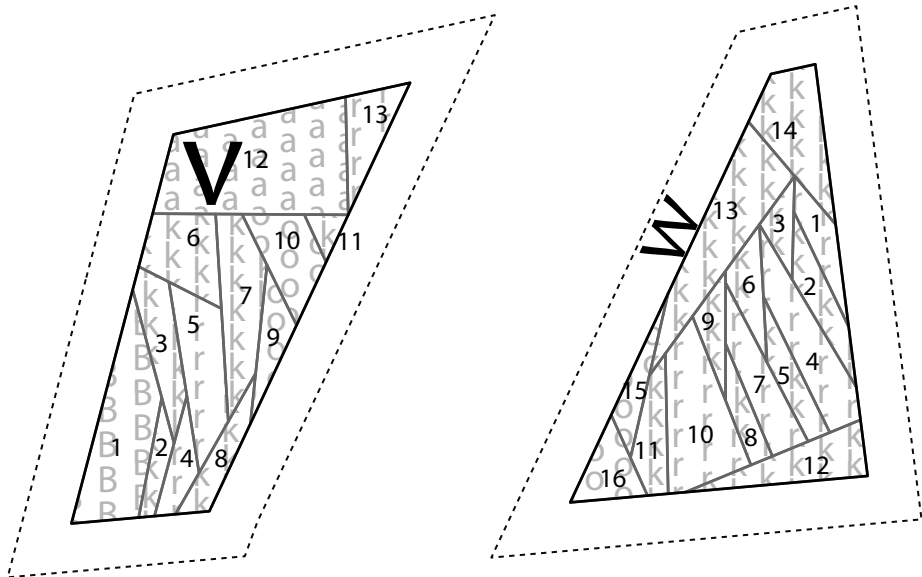
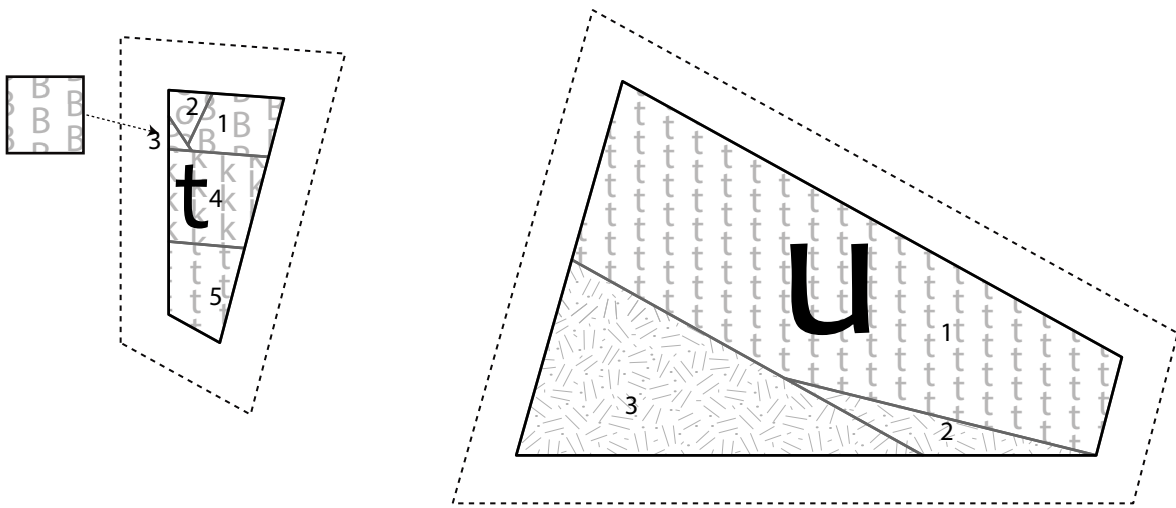
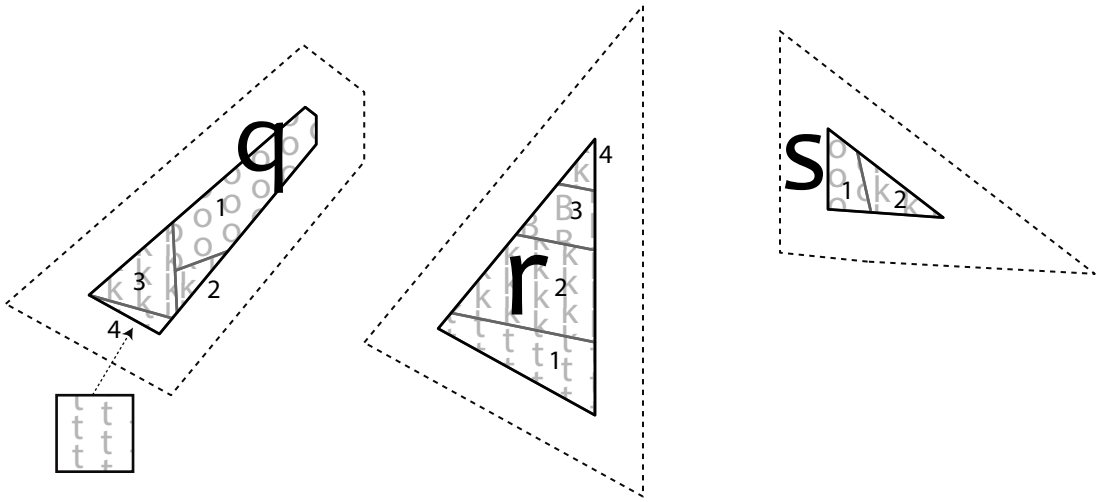

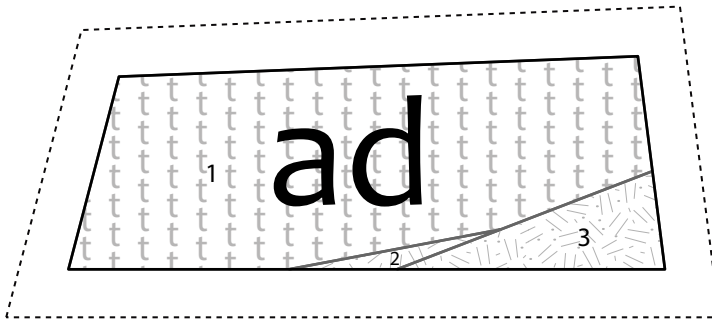
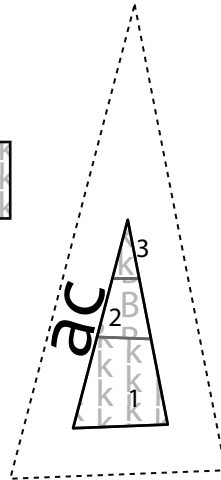
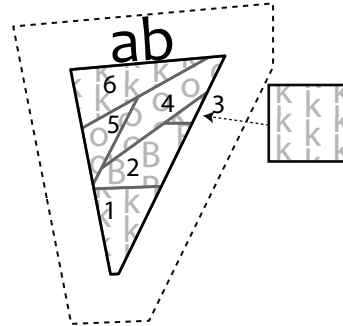
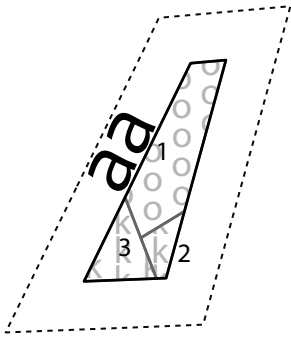
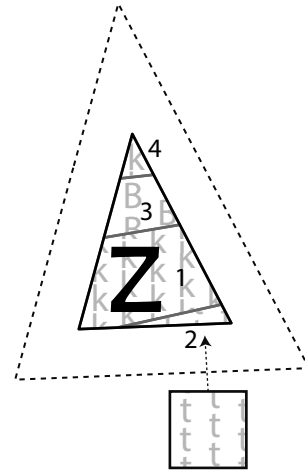
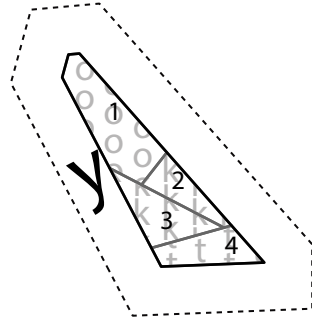
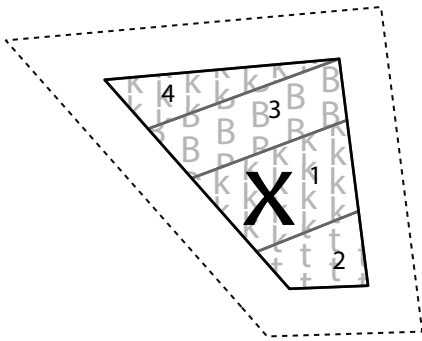

Coloring Page

Print to audition different color schemes for this pattern.

