

Resistance Birds: Alaska Willow Ptarmigan

Foundation Paper Piecing Pattern











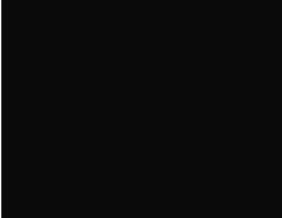
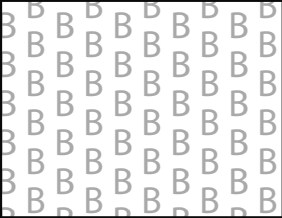

Finished Block: 12 inches x 12 inches

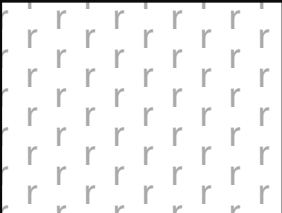

Coffee Town Quilting, LLC
coffeetownquilting.com | @coffeetownquilting

Color Guide and Fabric Chart

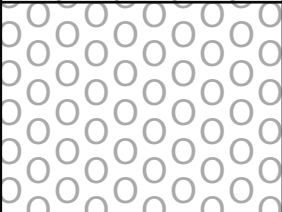
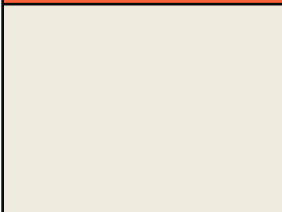
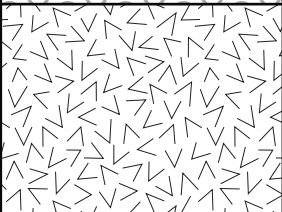
Color	Color Code	Yardage	Notes	Sample
		1/2 yard		Paste Fabric Sample Here
		1/2 yard		Paste Fabric Sample Here
		Fat Quarter		Paste Fabric Sample Here
		1/2 yard		Paste Fabric Sample Here
		Fat Quarter		Paste Fabric Sample Here
		Swatch		Paste Fabric Sample Here
		Fat Quarter		Paste Fabric Sample Here

Recommendations:

- **Since this design has many small pieces to accommodate the bird's details, batik or thinner fabric is recommended for best results.**
- This pattern assumes you already have knowledge of FPP and have completed beginning or intermediate designs.
- Color Guides are on page 2, print in color if able.
 - Cut small swatches of the fabric you will be using for each color code and paste them next to the corresponding square in the Color Guide grids.
 - Keep grid close to your cutting and sewing table as a legend and a reminder of which fabric is used for each color code.
 - The final page of the pattern is a grayscale and outline of the pattern, feel free to print and audition different color schemes according to your preference.
- Print the pattern pieces on newsprint paper if available for easy paper removal.
- Sew straight stitch with stitch length 1.5 - 2.0.
- Use an 80 wt or thinner thread for piecing to help keep seam bulk at minimum.
- In more complex areas with small pieces, consider trimming to 1/8" seam allowance.
- Remove paper backing from seam allowance before ironing when piecing separate sections together, this will help reduce bulk from sections pieced together and make final paper removal easier.
- Instructions and videos with helpful hints how to successfully line up and piece together cross seams across blocks are on my website coffeetownquilting.com.
- Once pieced, remove paper, spray liberally with ironing starch, and press well before adding border and quilting.

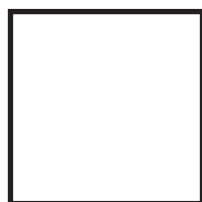

1 inch square:

Measure printed page to ensure measurement accuracy

Section Map

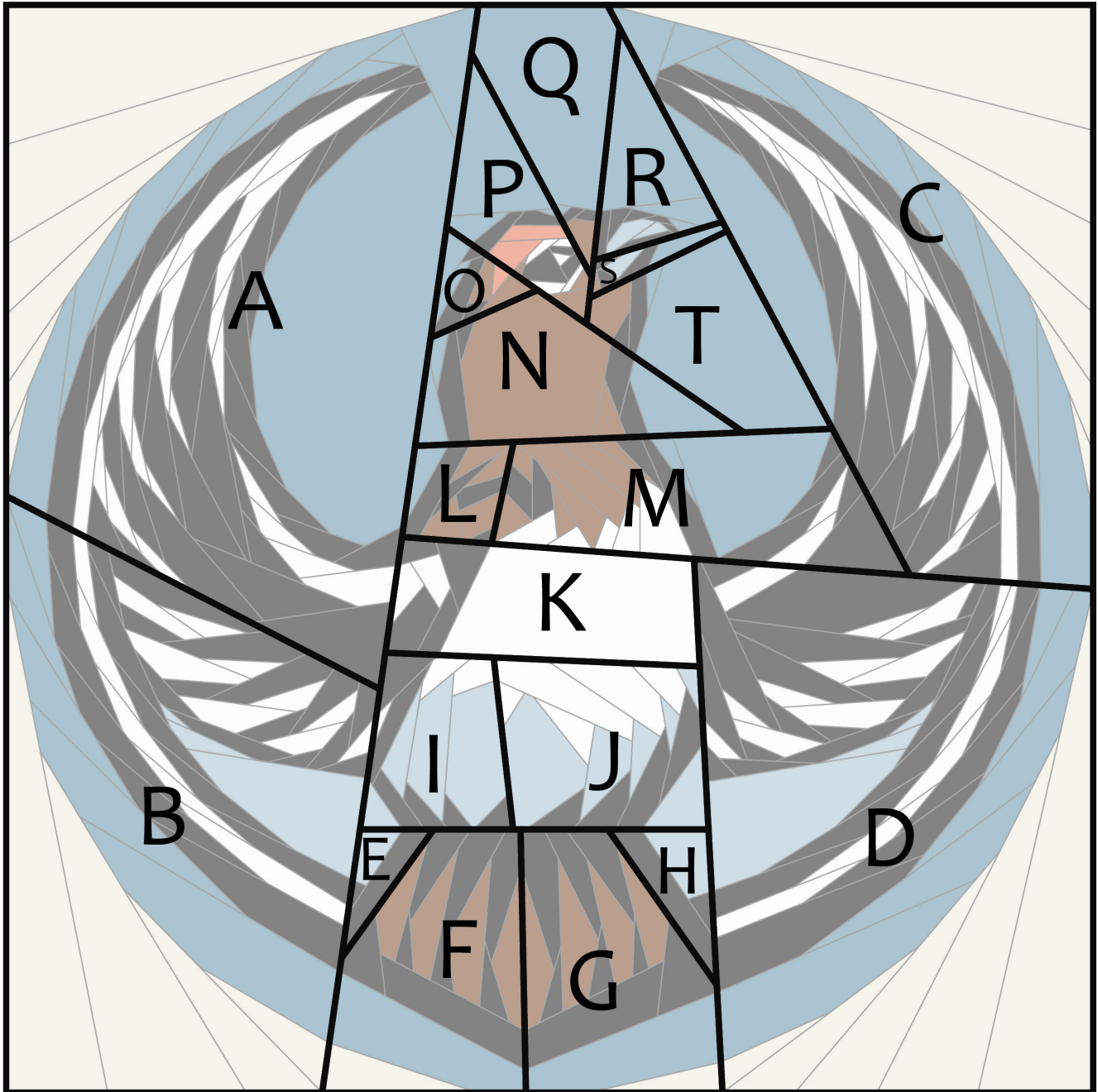

Section 1

1. A + B

Section 2

1. Q + P
2. R + S + T
3. QP + RST
4. (O + N) + QPRST
5. (L + M) + ONQRST
6. LMONPQRST + C

Section 3

1. K + (I + J)
2. E + F + G + H
3. KIJ + EFGH
4. KIJEFGH + D

Final Piecing

1. Section 2 + 3
2. Section 1 + Sections 2:3

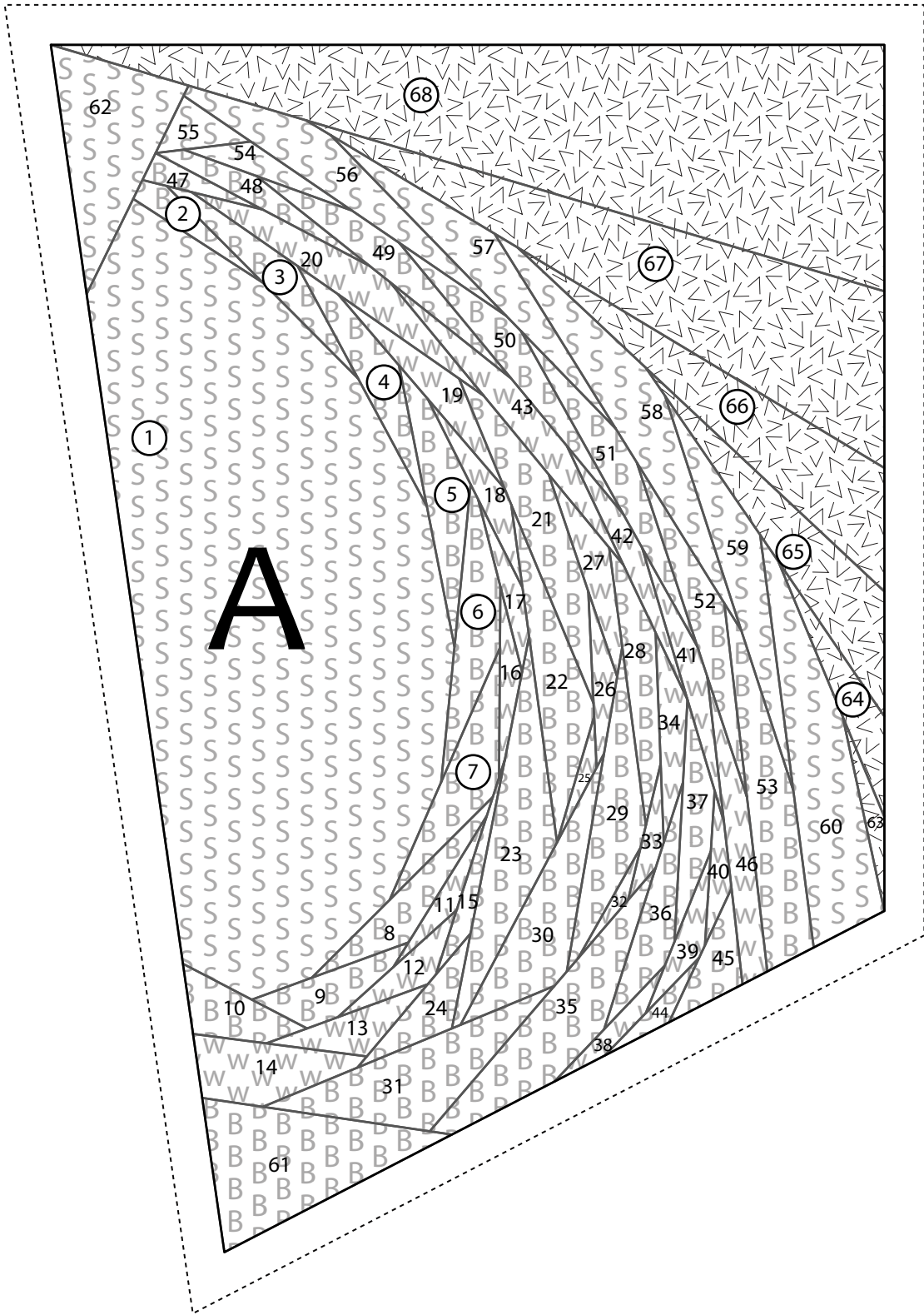

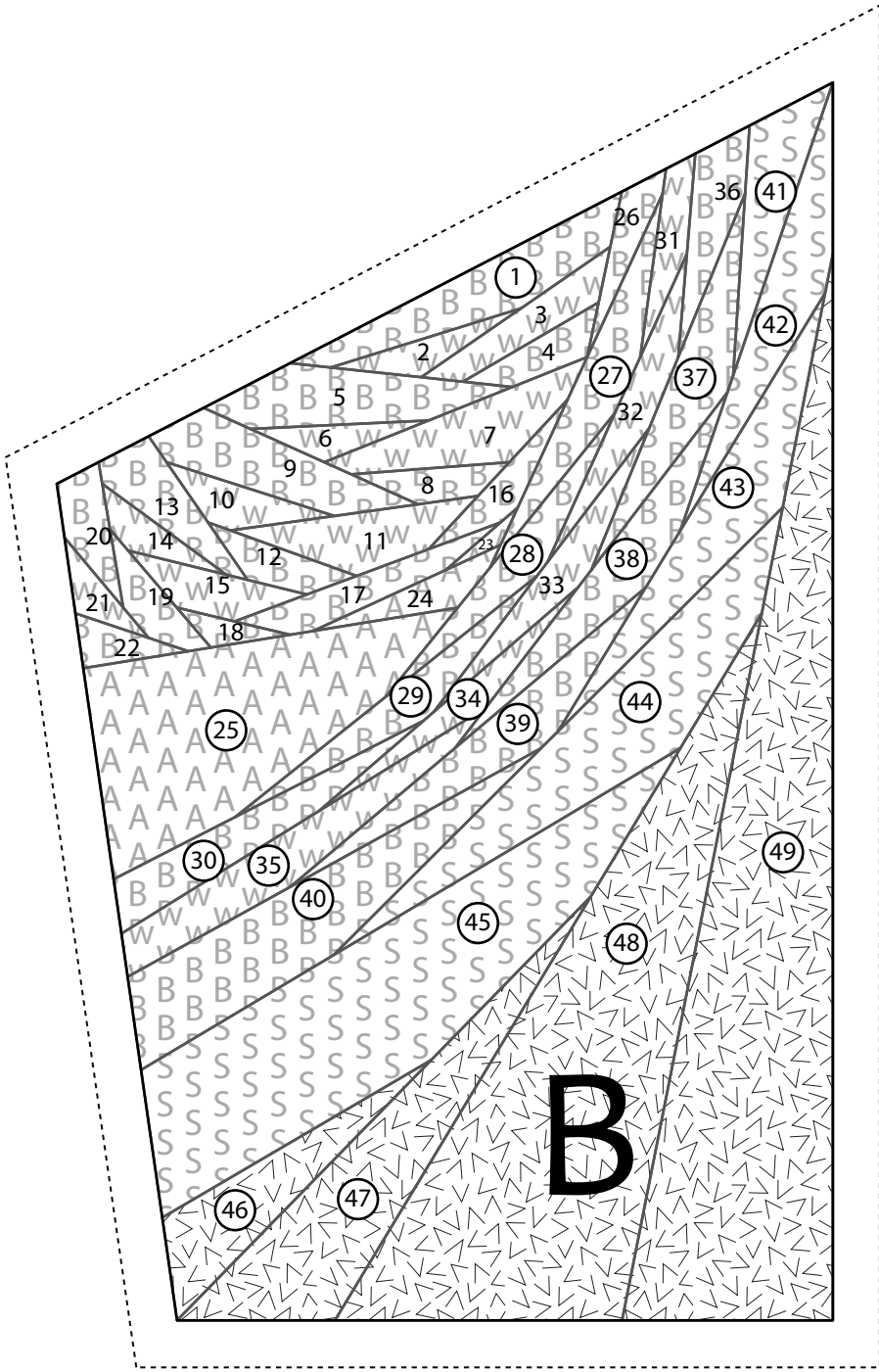

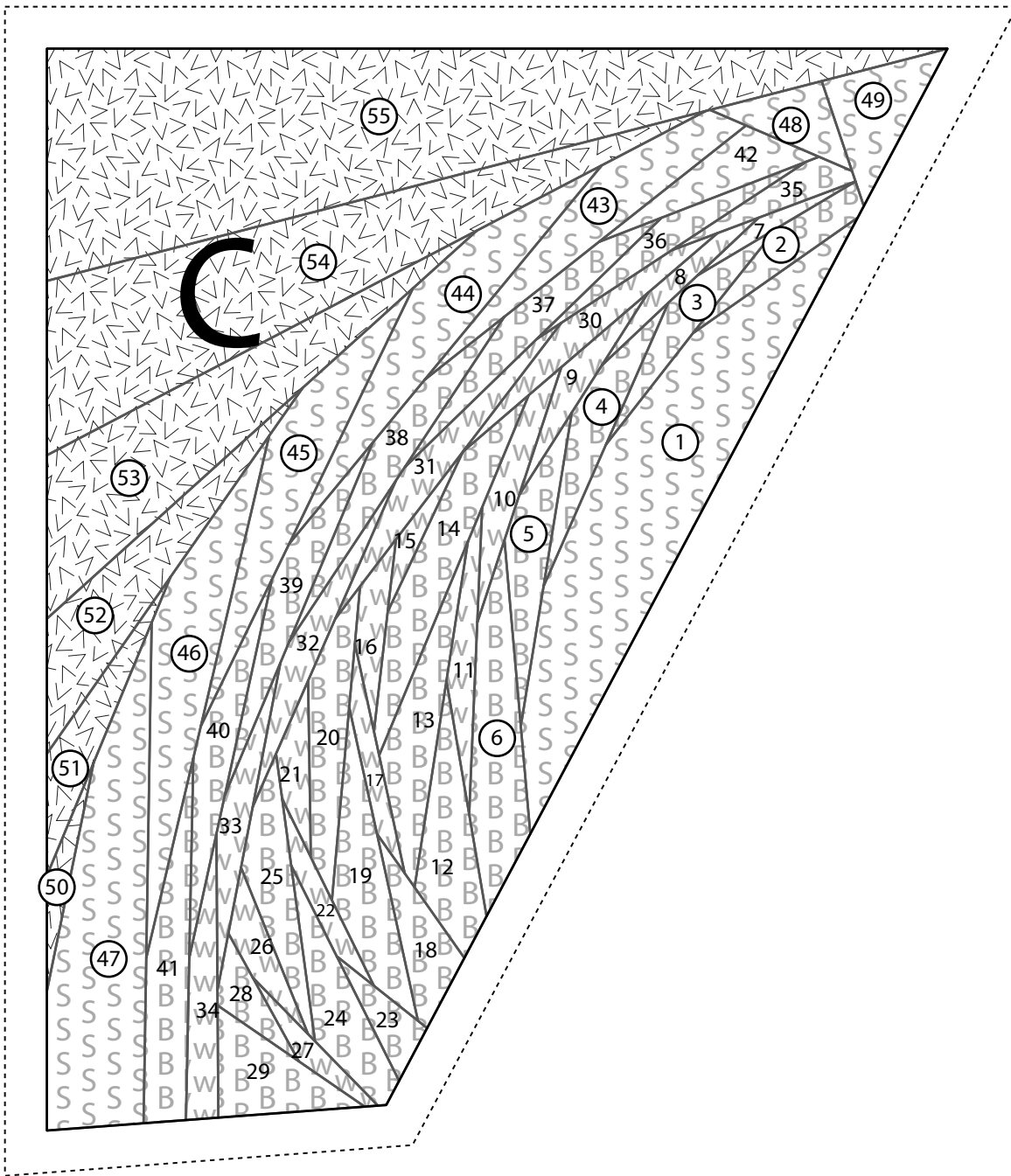

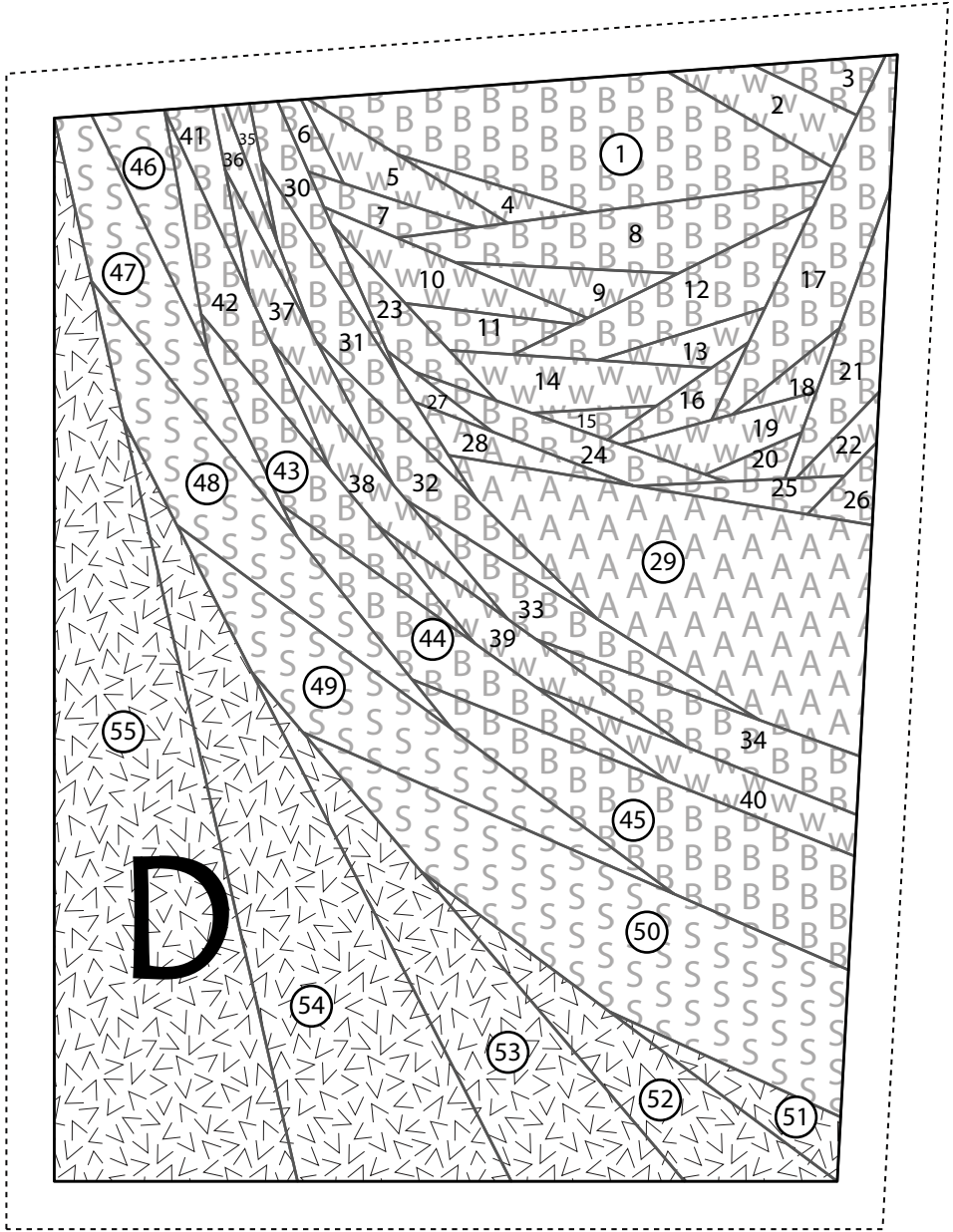

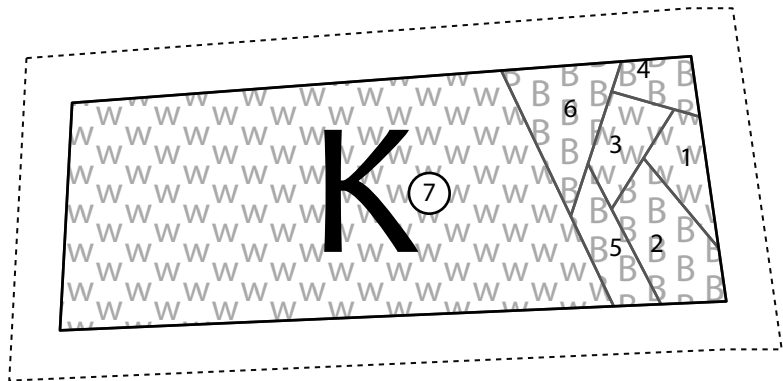
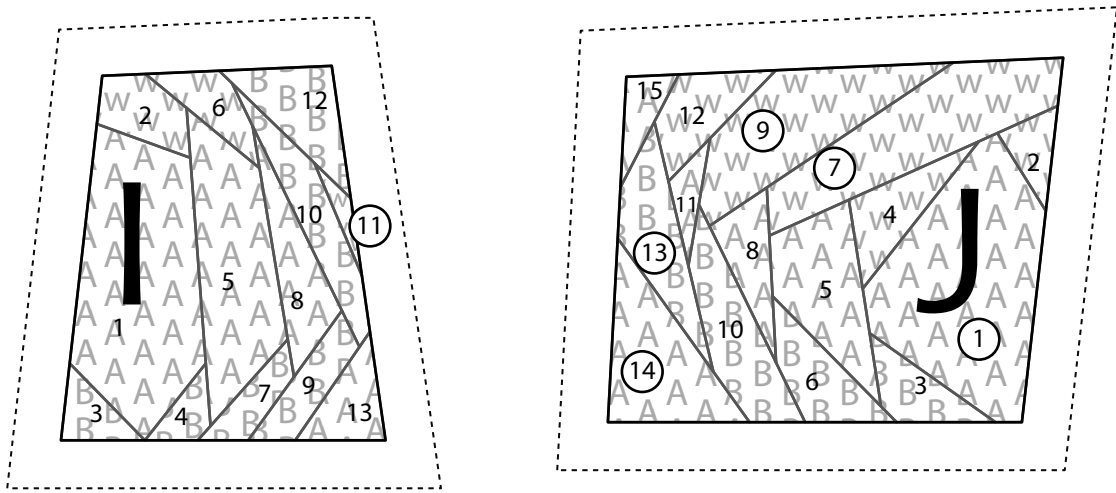
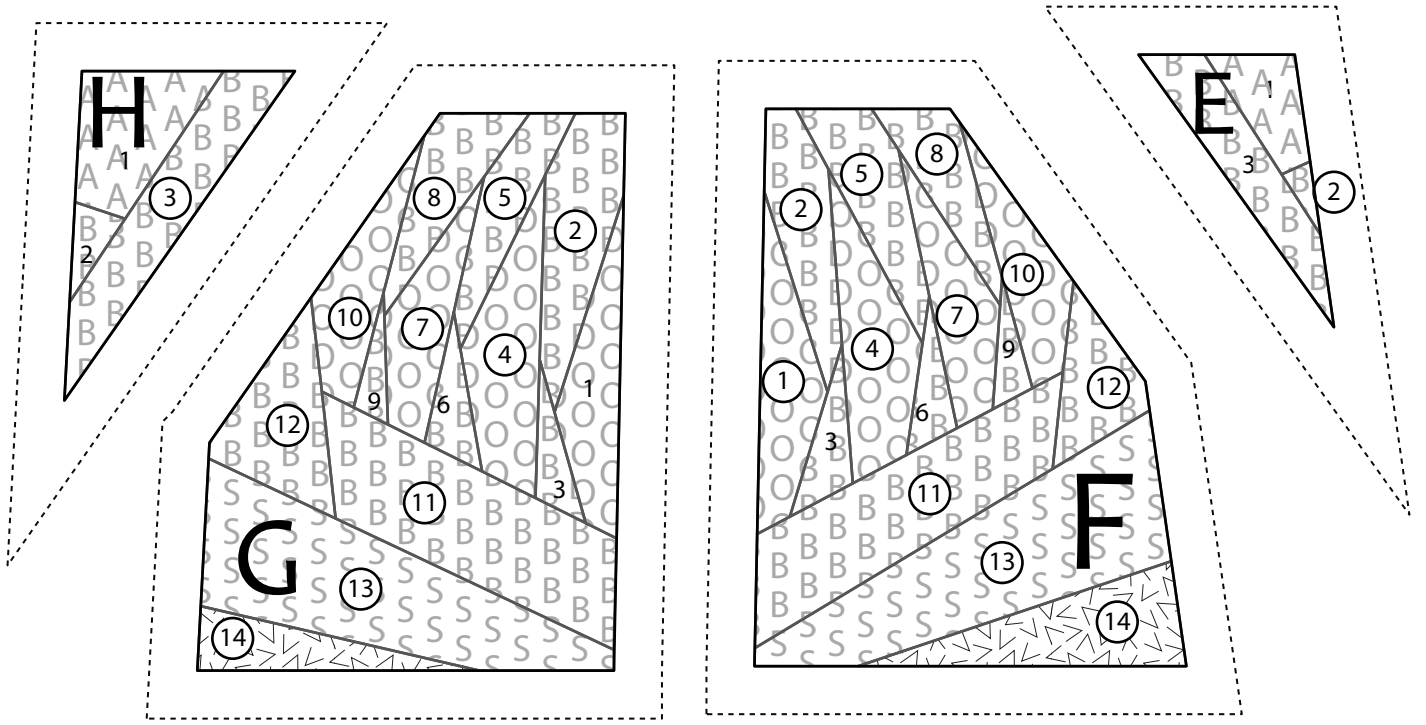

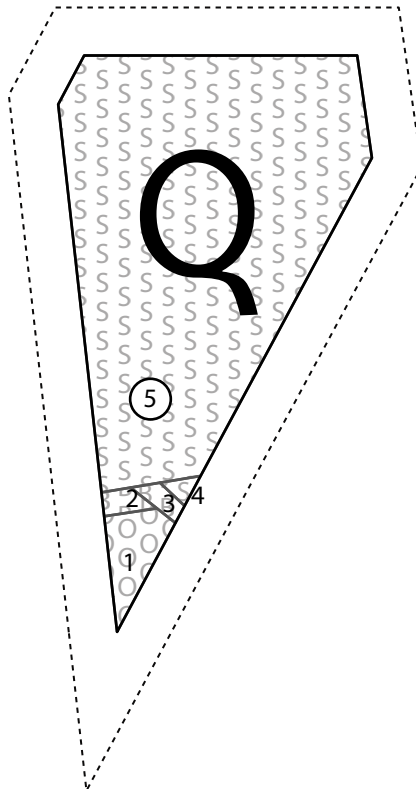
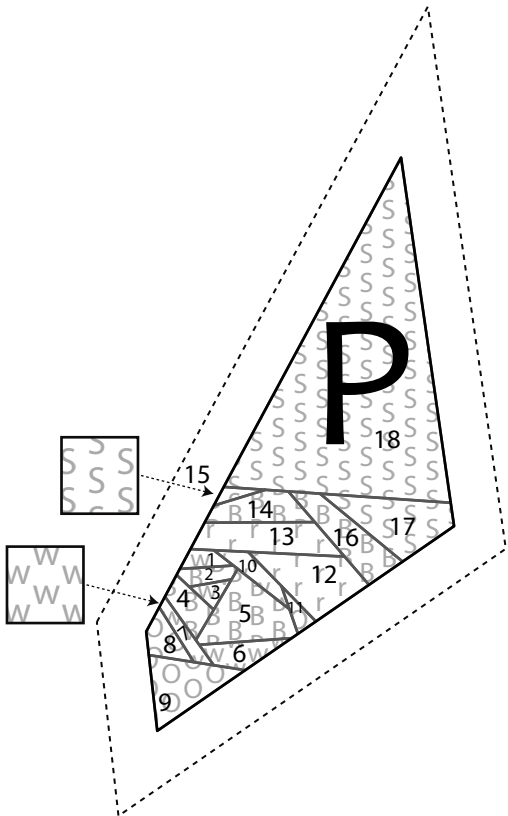
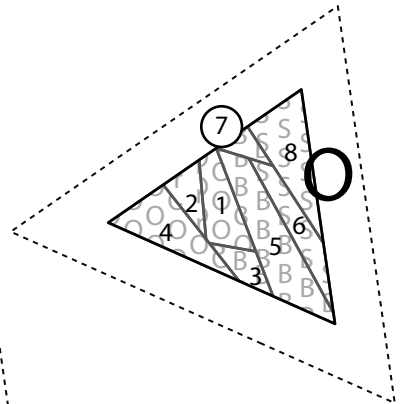
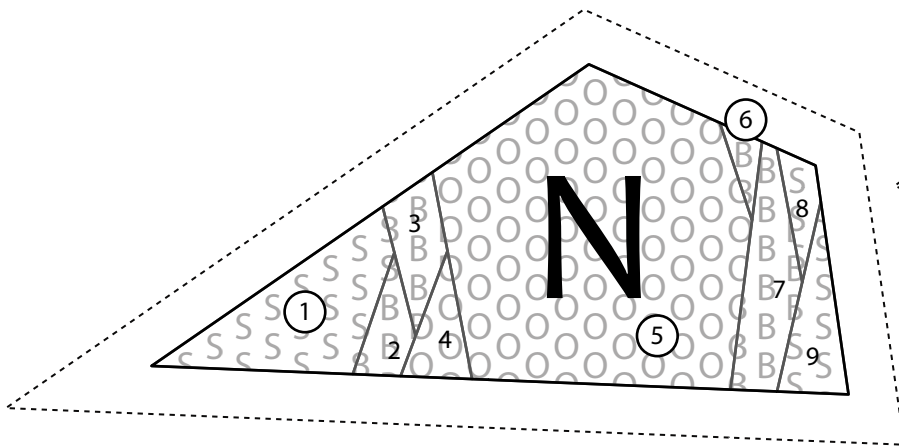
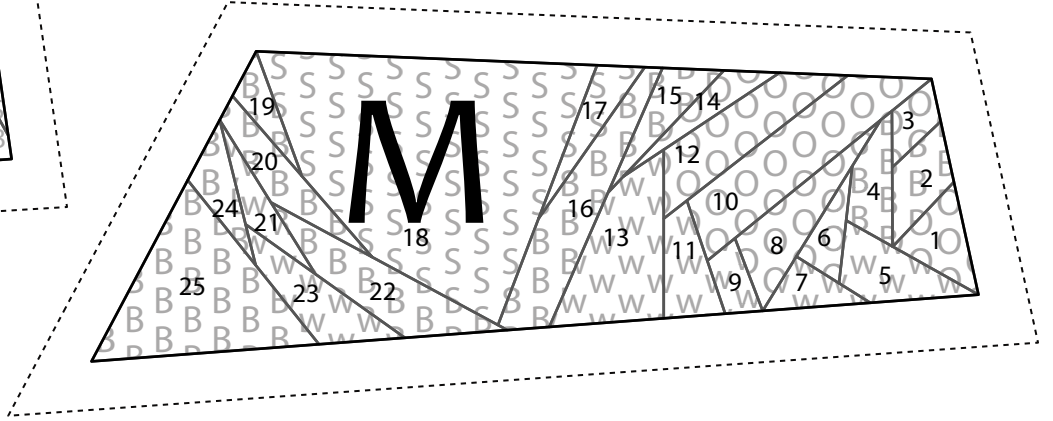
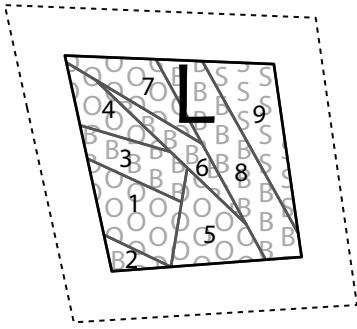

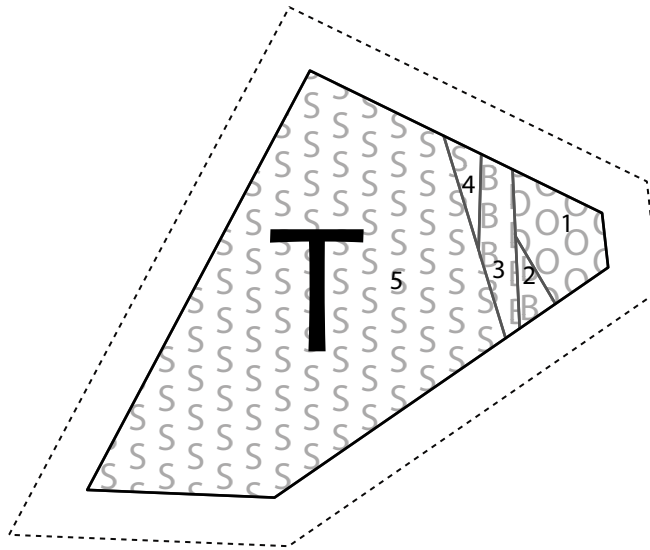
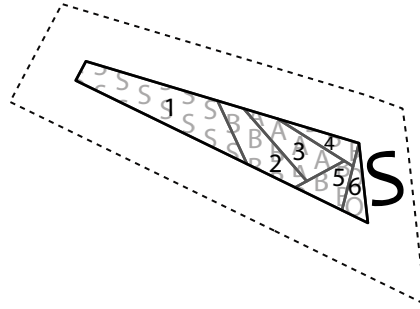
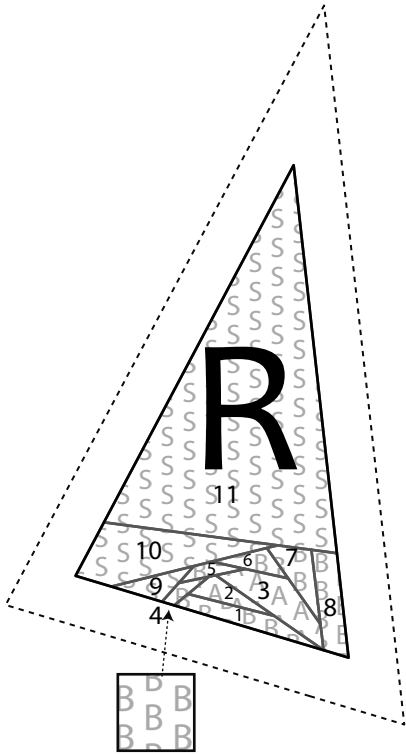

Coloring Page

Print to audition different color schemes for this pattern.

